

ST ANNES COLLEGE OF ENGINEERING AND TECHNOLOGY

**DEPARTMENT OF
ELECTRICAL AND ELECTRONICS ENGINEERING**

QUESTION BANK

V SEMESTER



EE3501-Power System Analysis

Regulation – 2021

Academic Year 2022-23

Prepared by

Dr. V. YOGAMBARI, Assistant Professor / EEE

ST ANNES COLLEGE OF ENGINEERING AND TECHNOLOGY

DEPARTMENT OF ELECTRICAL AND ELECTRONICS ENGINEERING

QUESTION BANK

UNIT I -POWER SYSTEM				
Need for system planning and operational studies - Power scenario in India - Power system components – Representation - Single line diagram - per unit quantities - p.u. impedance diagram - p.u. reactance diagram - Network graph, Bus incidence matrix, Primitive parameters, Bus admittance matrix from primitive parameters - Formation of bus admittance matrix of large power network Direct inspection method – Singular Transformation method..				
PART - A				
Q.No	Questions	Course Outcome	BT Level	Competence
1	What is meant by base quantities in per unit representation	CO 1	BT-1	Remember
2	What is impedance diagram and what are the approximation made in this diagram	CO 1	BT-2	Understand
3	Define bus admittance matrix, bus impedance matrix?	CO 1	BT-1	Remember
4	A generator rated 25MVA, 11KV has a reactance of 15%. Calculate its p.u. reactance for a base of 50MVA and 10KV	CO 1	BT-6	Create
5	What is single line diagram	CO 1	BT-2	Understand
6	Prepare the single phase equivalent circuit of three winding transformer	CO 1	BT-3	Apply
7	Point out the approximations made in impedance diagram?	CO 1	BT-4	Analyze
8	Write equation for per unit impedance if change base occurs	CO 1	BT-3	Apply
9	What is the need of base values	CO 1	BT-1	Remember
10	Contrast the π circuit representation of a transformer with off – nominal ratio ' α '	CO 1	BT-4	Analyze
11	What are the function of modern power system	CO 1	BT-2	Understand
12	How are the loads are represented in the reactance and impedance diagram	CO 1	BT-4	Analyze
13	Summarize the functions of power system analysis?	CO 1	BT-2	Understand
14	Examine the applications of Y-bus	CO 1	BT-5	Evaluate
15	Define Network graph.	CO 1	BT-1	Remember
16	Define off nominal transformer ratio?	CO 1	BT-1	Remember
17	Define primitive network?	CO 1	BT-1	Remember
18	Order the methods available for forming bus admittance matrix	CO 1	BT-5	Evaluate
19	Define Bus incidence matrix.	CO 1	BT-1	Remember
20	What is installed capacity of electrical power in India	CO 1	BT-6	Create
21	Prepare the list of advantages and disadvantages of sparse matrix in power systems.	CO 1	BT-4	Analyze
22	Define sparse matrix.	CO 1	BT-2	Understand
23	The per unit impedance of a circuit element is 0.30. If the base kV and base MVA are halved, then the new value of the per unit impedance of the circuit element will be	CO 1	BT-4	Analyze
24	The per unit value of a 2 ohm resistor at 100 MVA base and 10 kV base voltage is	CO 1	BT-4	Analyze
PART - B				

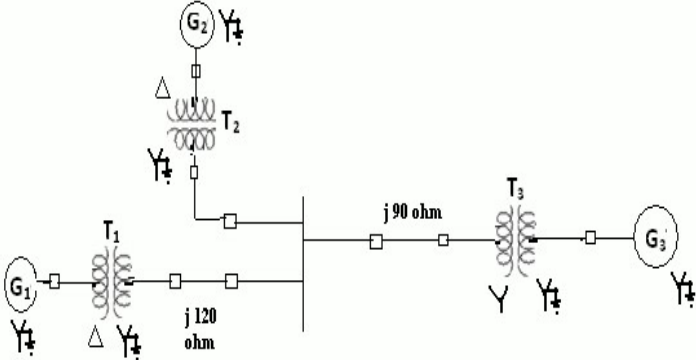
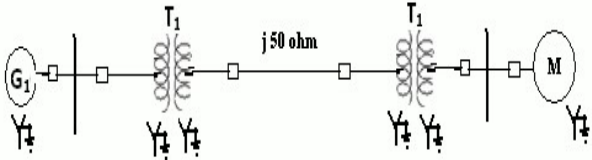
1	<p>The single line diagram of a simple power system is shown in Fig. The rating of the generators and transformers are given below:</p> <p>Generator 1: 25MVA, 6.6KV, $X=0.2p.u$ Generator 2: 5MVA, 6.6KV, $X=0.15p.u$ Generator 3: 30MVA, 13.2KV, $X=0.15p.u$ Transformer1: 30MVA, 6.9Δ/115Y KV, $X=10\%$ Transformer2: 15MVA, 6.9Δ/115Y KV, $X=10\%$ Transformer3: Single phase units each rated 10MVA, 6.9/69 KV, $X=10\%$</p> <p>Examine the impedance diagram and mark all values in p.u choosing a base of 30MVA, 6.6KV in the generator 1 circuit. (13)</p> 	CO 1	BT-2	Understand
2	<p>Examine the reactance diagram for the power system shown in fig. Neglect resistance and use a base of 100MVA, 220kV in 50Ω line. The ratings of the generator motor and transformer are give below. (13)</p>  <p>Generator: 40MVA, 25KV, $X'' = 20\%$. Synchronous Motor: 50MVA, 11KV, $X'' = 30\%$ T1: Y-Y transformer : 40MVA 33/220KV, $X=15\%$ T2: Y- Y transformer : 30 MVA 11/220KV, $X=15\%$</p>	CO 1	BT-3	Apply

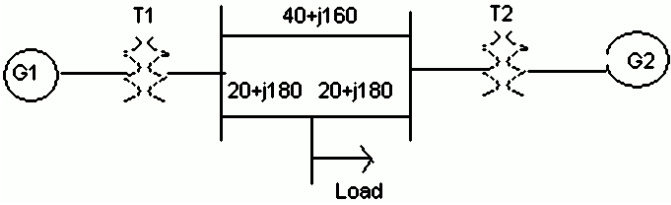
3	<p>Prepare a per phase schematic of the system in fig. and show all the impedance in per unit on a 100 MVA, 132 KV base in the transmission line circuit. The necessary data are Given as follows. (13)</p> <p>G1 : 50MVA, 12.2KV, X=0.15 pu. G2 : 20MVA, 13.8KV, X=0.15 pu. T1 : 80MVA, 12.2/161KV, X=0.1 pu. T2 : 40MVA, 13.8/161KV, X=0.1 pu. LOAD: 50MVA, 0.8 power factor lag operating at 154KV. Evaluate the p.u impedance of the load.</p> 	CO 1	BT-2	Understand																														
4	<p>(i) The parameters of a four system are as under:</p> <table border="1" data-bbox="277 709 967 1041"> <thead> <tr> <th>Line No.</th> <th>Line starting bus</th> <th>Line ending bus</th> <th>Line impedance(pu)</th> <th>Line Charging Admittance(pu)</th> </tr> </thead> <tbody> <tr> <td>1</td> <td>1</td> <td>2</td> <td>0.2+j0.8</td> <td>j0.02</td> </tr> <tr> <td>2</td> <td>2</td> <td>3</td> <td>0.3+j0.9</td> <td>j0.03</td> </tr> <tr> <td>3</td> <td>2</td> <td>4</td> <td>0.25+j1.0</td> <td>j0.04</td> </tr> <tr> <td>4</td> <td>3</td> <td>4</td> <td>0.2+j0.8</td> <td>j0.02</td> </tr> <tr> <td>5</td> <td>1</td> <td>3</td> <td>0.1+j0.4</td> <td>j0.01</td> </tr> </tbody> </table> <p>Point out the Network and find bus admittance matrix. (10)</p> <p>(ii) Generalize the impedance and reactance diagram? Explain with assumptions. (3).</p>	Line No.	Line starting bus	Line ending bus	Line impedance(pu)	Line Charging Admittance(pu)	1	1	2	0.2+j0.8	j0.02	2	2	3	0.3+j0.9	j0.03	3	2	4	0.25+j1.0	j0.04	4	3	4	0.2+j0.8	j0.02	5	1	3	0.1+j0.4	j0.01	CO 1	BT-3	Apply
Line No.	Line starting bus	Line ending bus	Line impedance(pu)	Line Charging Admittance(pu)																														
1	1	2	0.2+j0.8	j0.02																														
2	2	3	0.3+j0.9	j0.03																														
3	2	4	0.25+j1.0	j0.04																														
4	3	4	0.2+j0.8	j0.02																														
5	1	3	0.1+j0.4	j0.01																														
5	<p>(i) Discuss the primitive network matrix and represent its forms? Prove $Y_{bus} = A^t [y] A$ using singular transformation? (7)</p> <p>ii) Estimate the Y_{bus} for the given network:</p> <table border="1" data-bbox="367 1377 846 1591"> <thead> <tr> <th>Element</th> <th>Positive sequence reactance</th> </tr> </thead> <tbody> <tr> <td>1-2</td> <td>j1.0</td> </tr> <tr> <td>2-3</td> <td>j0.4</td> </tr> <tr> <td>2-4</td> <td>j0.2</td> </tr> <tr> <td>3-4</td> <td>j0.2</td> </tr> <tr> <td>3-1</td> <td>j0.8</td> </tr> <tr> <td>4-5</td> <td>j0.08</td> </tr> </tbody> </table> <p>(6)</p>	Element	Positive sequence reactance	1-2	j1.0	2-3	j0.4	2-4	j0.2	3-4	j0.2	3-1	j0.8	4-5	j0.08	CO 1	BT-4	Analyze																
Element	Positive sequence reactance																																	
1-2	j1.0																																	
2-3	j0.4																																	
2-4	j0.2																																	
3-4	j0.2																																	
3-1	j0.8																																	
4-5	j0.08																																	
6	<p>(i) Show that the per unit equivalent impedance of a two winding transformer is the same whether the calculation is made from the high voltage side or the low voltage side (7)</p> <p>(ii) Explain the π model for a transformer with off nominal tap ratio. (6)</p>	CO 1	BT-1	Remember																														

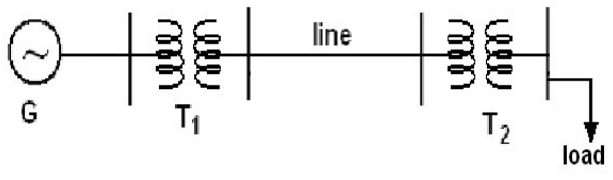
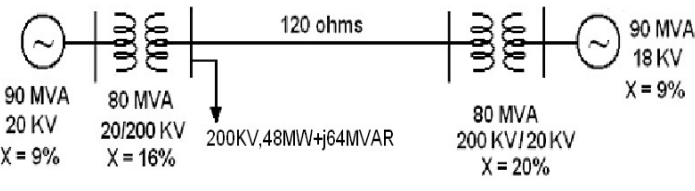
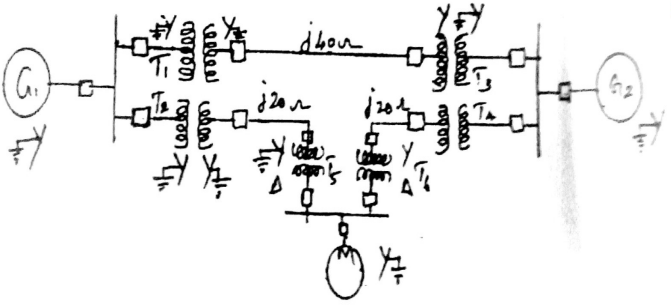
7	<p>Give p.u impedance diagram of the power system of figure. Choose base quantities as 15 MVA and 33 KV.</p> <p>Generator: 30 MVA, 10.5 KV, $X = 1.6$ ohms. Transformers T1 & T2: 15 MVA, 33/11 KV, $X = 15$ ohms referred to HV Transmission line: 20 ohms / phase. Load: 40 MW, 6.6 KV, 0.85 lagging p.f. (13)</p> 	CO 1	BT-4	Analyze
8	<p>Draw the p.u impedance diagram for the system shown in figure. Choose Base MVA as 100 MVA and Base KV as 20 KV. (13)</p> 	CO 1	BT-5	Evaluate
9	<p>Draw the reactance diagram for the power system shown in figure. The ratings of generator, motor and transformers are given below. Neglect resistance and use a base of 50MVA, 13.8kV in the 40 ohm line</p>  <p>Generator G1: 20MVA, 18kV, $X''=20\%$ Generator G2: 40MVA 18kV, $X''=20\%$ Synchronous motor: 30MVA, 13.8kV, $X''=20\%$ 3phase Y-Y Transformer: 20MVA 13.8/20kV, $X=10\%$ 3 phase Y-Y Transformer: 15MVA, 138/13.8kV, $X=10\%$ (13)</p>	CO 1	BT-1	Remember
10	<p>(i). Explain the structure of modern power system with neat sketch. (7)</p> <p>(ii). Describe about representation of loads. (6)</p>	CO 1	BT-1 BT-1	Remember Remember

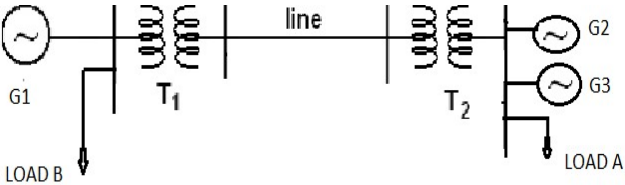
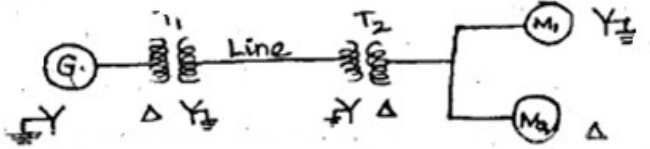
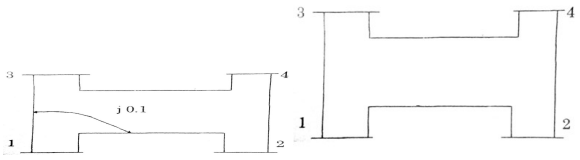
<p>11</p>	<p>(i) Estimate the per unit impedance diagram shown in fig below.</p>  <p>Generator1: 30MVA, 10.5KV, $X'' = 1.6$ ohms Generator2: 15MVA, 6.6KV, $X'' = 1.2$ ohms Generator3: 25MVA, 16.6KV, $X'' = 0.56$ ohms Transformer $T_1(3\Phi)$: 15MVA, 33/11 KV, $X = 15.2$ HT Side Transformer $T_2(3\Phi)$: 15MVA, 33/6.2 KV, $X = 16$ HT Side Transmission line: $20.5\Omega/\text{phase}$ Load A: 15MW, 11KV, 0.9 LPF Load B: 40MW, 6.6KV, 0.85 LPF</p> <p>(ii). Express the per unit equivalent circuit of single phase transformer? (6)</p>	<p>CO 1</p>	<p>BT-6</p>	<p>Create</p>															
<p>12</p>	<p>A 90 MVA 11KV 3Φ generator has a reactance of 25%. The generator supplies two motors through transformer and transmission line as shown in fig. The transformer T1 is a 3Φ transformer, 100 MVA, 10/132 KV, 6% reactance. The transformer T2 is composed of 3 single phase units each rated, 300 MVA, 66/20 KV, with 5% reactance. The connection of T1 and T2 are shown in fig. The motors are rated at 50 MVA and 400 MVA both 10KV and 20% reactance. Taking the generator rating as base. Show reactance diagram. Reactance of the line is 100Ω. (13)</p> 	<p>CO 1</p>	<p>BT-5</p>	<p>Evaluate</p>															
<p>13</p>	<p>Form Y bus of the test system shown in figure using singular transformation method. The impedance data is given in Table Take (1) as reference node (13)</p>  <table border="1" data-bbox="276 1627 665 1827"> <thead> <tr> <th>Element No</th> <th>Bus code</th> <th>Self Impedance</th> </tr> </thead> <tbody> <tr> <td>1</td> <td>1-2</td> <td>0.5</td> </tr> <tr> <td>2</td> <td>1-3</td> <td>0.6</td> </tr> <tr> <td>3</td> <td>3-4</td> <td>0.4</td> </tr> <tr> <td>4</td> <td>2-4</td> <td>0.3</td> </tr> </tbody> </table>	Element No	Bus code	Self Impedance	1	1-2	0.5	2	1-3	0.6	3	3-4	0.4	4	2-4	0.3	<p>CO 1</p>	<p>BT-3</p>	<p>Apply</p>
Element No	Bus code	Self Impedance																	
1	1-2	0.5																	
2	1-3	0.6																	
3	3-4	0.4																	
4	2-4	0.3																	

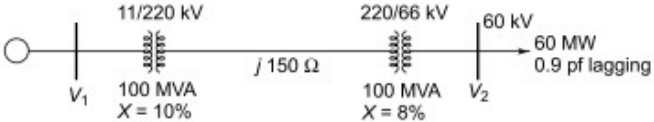
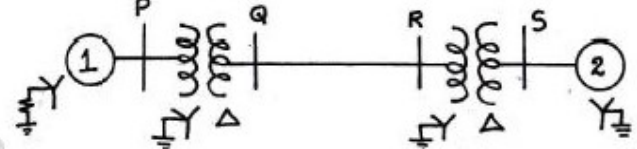
14	<p>(i) The sub transient reactance of a 500MVA, 18kV generator is 0.25p.u on its rating. It is connected to a network through a 20/400kV transformer. Find out the sub transient reactance of the generator on a base of 100MVA and 20kV</p> <p>(ii) A transformer interconnects a strong 400kV and weaker 200kV system and is provided with a tap changer on the 400 kV side. What is the effect of setting the tap such that the voltage ratio is 410/200kV on the 400 and 200kV sides</p> <p>(iii) Draw the pu reactance diagram of a three winding transformer whose three phase rating are: primary wye-grounded 15MVA,66kV Secondary (S) wye-grounded,10MVA 13.2 kV tertiary (t) delta connected 5 MVA 2.3 kV. Mark the appropriate value of the impedance are ZPS=7% ON 15MV;ZPT=9% on 15 MVA and 66KV ST=8% ON 10MVA and 13.2kV</p>	CO 1	BT-2	Understand
15	<p>Figure shows the schematic diagram of a radial transmission system. The ratings and reactance of the various components are shown there in. A load of 60 MW at 0.9 power factor lagging is tapped from the 66 kV substation which is to be maintained at 60 kV. Calculate the terminal voltage of the synchronous machine. Represent the transmission line and the transformers by series reactance only.</p> 	CO 1	BT-3	Apply
16	<p>One line diagram of a simple power system is given below. Draw the zero sequence network.</p> <p>The zero sequence reactances of the various components are denoted as follows: Generator 1 = X_{10} , Transformer X_{T1} □ and line = X_l . Generator 2 = X_{20} , Transformer X_{T2} □</p> 	CO 1	BT-2	Understand

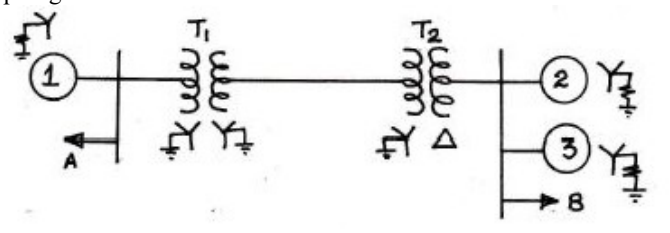
17	<p>Obtain the per unit reactance diagram of the power system shown below.</p> <p>Specifications of the system components are Generator 1: 30MVA, 10.5 kV, $X'' = 1.6\Omega$ Generator 2: 15MVA, 6.6 kV, $X'' = 1.2\Omega$ Generator 3: 25MVA, 6.6 kV, $X'' = 0.56\Omega$ Transformer T1: 15MVA, 11/33 kV, $X = 15.2\Omega$ per phase on HV side Transformer T2: 15MVA, 33/6.2 kV, $X = 16\Omega$ per phase on HV side, Transmission Line: 20.5 ohms per phase Load A: 40 MW, 11 kV, 0.9 pf lag and Load B: 40 MW, 6.6 kV, 0.5 pf lag</p> 	CO 1	BT-5	Evaluate
----	--	------	------	----------

PART - C

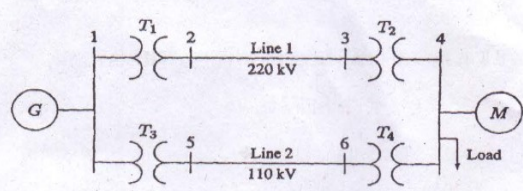
1	<p>The one diagram of three phase power system in figure. Select a common base of 100MVA and 22kV on generator side draw the impedance diagram in per unit</p> <p>The three phase load at bus 4 absorbs 57 MVA, 0.6 power factor lagging at 10.45kV. Line 1 and line 2 reactance of 48.4Ω and 65.43Ω respectively</p> <p>G : 90 MVA, 22 KV, $X = 18\%$; T1 : 50 MVA, 22/220 KV, $X = 10\%$ T2 : 40 MVA, 22/220 KV, $X = 6\%$; T3 : 40 MVA, 220/110 KV, $X = 6.4\%$ T4 : 40 MVA, 110/11 KV, $X = 8\%$; M : 66.5 MVA, 10.45 KV, $X = 18.5\%$</p>  <p align="right">(15)</p>	CO 1	BT-5	Evaluate																								
2	<p>The parameter of a 4 bus system are as under</p> <table border="1" data-bbox="276 1449 941 1680"> <thead> <tr> <th>Starting Bus</th> <th>Ending bus</th> <th>Line impedance</th> <th>Line charging admittance</th> </tr> </thead> <tbody> <tr> <td>1</td> <td>2</td> <td>$0.25+j0.8$</td> <td>$j0.02$</td> </tr> <tr> <td>2</td> <td>3</td> <td>$0.35+j0.9$</td> <td>$j0.03$</td> </tr> <tr> <td>2</td> <td>4</td> <td>$0.25+j1.0$</td> <td>$j0.04$</td> </tr> <tr> <td>3</td> <td>4</td> <td>$0.25+j0.8$</td> <td>$j0.02$</td> </tr> <tr> <td>1</td> <td>3</td> <td>$0.15+j0.4$</td> <td>$j0.01$</td> </tr> </tbody> </table> <p>Draw the network and find admittance matrix (15)</p>	Starting Bus	Ending bus	Line impedance	Line charging admittance	1	2	$0.25+j0.8$	$j0.02$	2	3	$0.35+j0.9$	$j0.03$	2	4	$0.25+j1.0$	$j0.04$	3	4	$0.25+j0.8$	$j0.02$	1	3	$0.15+j0.4$	$j0.01$	CO 1	BT-5	Evaluate
Starting Bus	Ending bus	Line impedance	Line charging admittance																									
1	2	$0.25+j0.8$	$j0.02$																									
2	3	$0.35+j0.9$	$j0.03$																									
2	4	$0.25+j1.0$	$j0.04$																									
3	4	$0.25+j0.8$	$j0.02$																									
1	3	$0.15+j0.4$	$j0.01$																									

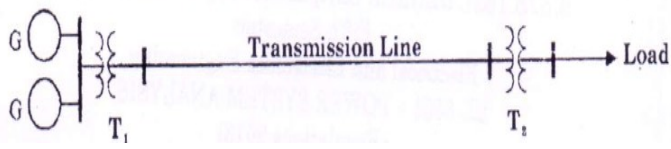
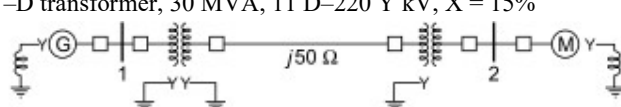
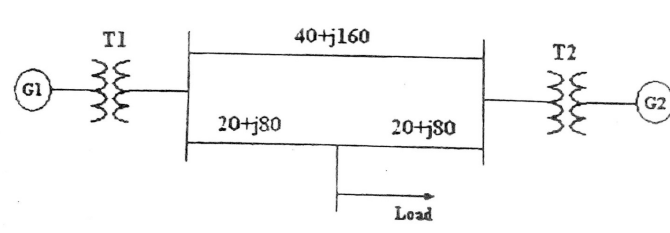
<p>3</p>	<p>(i) In this line diagram shown in figure each three phase generator G is rated at 200MVA, 13.8kV and has reactance of 0.85p.u and are generating 1.15pu. Transformer T1 is rated 500MVA, 13.5kV/220kV and has reactance of 0.8%. The transmission line has a reactance of 7.8Ω. Transformer T2 has rating of 400MVA, 220kV/33kV and a reactance of 11%. The load is 250MVA at a power factor of 0.85lag. Convert all quantities to a common base of 500MVA and 220kV on the line and draw the circuit diagram with values expressed in pu (12)</p>  <p>(ii) A 200MVA, 13.8kV generator has a reactance of 0.85p.u and is generating 1.1.5pu voltages. Determine the actual values of the line voltage and phase voltage and reactance (3)</p>	<p>CO 1</p>	<p>BT-6</p>	<p>Create</p>
<p>4</p>	<p>Draw the pu impedance diagram for the power system shown in Fig. Neglect resistance, and use a base of 100 MVA, 220 kV in 50 W line. The ratings of the generator, motor and transformers are Generator 40 MVA, 25 kV, $X'' = 20\%$ Motor 50 MVA, 11 kV, $X'' = 30\%$ Y-Y transformer, 40 MVA, 33 Y -220 Y kV, $X = 15\%$ Y-D transformer, 30 MVA, 11 D-220 Y kV, $X = 15\%$</p> 	<p>CO 1</p>	<p>BT-5</p>	<p>Evaluate</p>
<p>5</p>	<p>Prepare a per phase schematic of the system shown in figure and show all the impedance in per unit on a 100 MVA, 132 kV base in the transmission line circuit. The necessary data are given follows</p> <p>G1: 50MVA 12.2kV $X=0.15p.u$ G2: 20MVA, 13.8kV, $X=0.15p.u$ T1: 80 MVA 12.2/161 kV, $X=0.1p.u$ T2: 40MVA, 13.8/161kV, $X=0.1p.u$ Load: 50MVA, 0.8 pf lag operating at 154 kV</p> <p>Determine the p.u impedance of the load</p> 	<p>CO 1</p>	<p>BT-6</p>	<p>Create</p>

UNIT II- POWER FLOW ANALYSIS

Bus classification - Formulation of Power Flow problem in polar coordinates - Power flow solution using Gauss Seidel method - Handling of Voltage controlled buses - Power Flow Solution by Newton Raphson method. Flow charts – Comparison of methods..

PART - A

Q.No	Questions	Course Outcome	BT Level	Competence
1	What is the information that are obtained from a load flow study	CO 2	BT-1	Remember
2	What is the need for slack bus in power flow analysis	CO 2	BT-4	Analyze
3	When will the generator bus is treated as load bus	CO 2	BT-2	Understand
4	Extend the acceleration factor in Gauss Seidal Method	CO 2	BT-5	Evaluate
5	Prepare the advantages and disadvantages of Gauss Seidal method	CO 2	BT-3	Apply
6	What is the need for load flow analysis	CO 2	BT-1	Remember
7	Associate with load flow studies are important for planning the existing system as well as the future expansion	CO 2	BT-2	Understand
8	When the generator bus treated as load bus in NR load flow study? What will be the reactive power and bus voltage when the generator bus is treated as load bus.	CO 2	BT-3	Apply
9	Show the general power flow equation.	CO 2	BT-4	Analyze
10	What is swing bus.	CO 2	BT-1	Remember
11	Compare GSM and NRM with respect to number of iterations taken for convergence and memory requirement	CO 2	BT-4	Analyze
12	Discuss the effect of acceleration factor in the load flow solution algorithm	CO 2	BT-2	Understand
13	What are the disadvantage NR method	CO 2	BT-3	Apply
14	Define Acceleration Value..	CO 2	BT-1	Remember
15	Compare GS and NR method.	CO 2	BT-5	Evaluate
16	Explain what do you mean by flat voltage start	CO 2	BT-6	Create
17	Mentioned the various types of buses in power system with specified quantitates for each bus	CO 2	BT-1	Remember
18	Mentioned the various types of buses in power system with specified quantitates for each bus	CO 2	BT-6	Create
19	What is jacobian matrix	CO 2	BT-2	Understand
20	Define voltage-controlled bus and load bus	CO 2	BT-1	Remember
21	Classify types of buses in the power network?	CO 2	BT-3	Apply
22	Show the power balance equation.	CO 2	BT-1	Remember
23	Describe how the convergence of Newton Raphson method is speeded up.	CO 2	BT-5	Evaluate
24	Recommend the necessity of a slack bus?	CO 2	BT-6	Create
PART - B				
1	Prepare the load flow algorithm using Gauss Seidal method with flow chart and discuss the advantages of the method. (13)	CO 2	BT-1	Remember

2

For the same system shown in the fig. the generators are connected at all four buses while the loads are at buses 2 and 3. Assuming a flat voltage start, examine bus voltages and bus angles at the end of first Gauss seidal iterations and consider the reactive power limits $0.2 \leq Q \leq 1$. (13)

CO 2

BT-3

Apply

Bus	P in pu	Q in pu	V in pu	Remarks
1	-	-	$1.04 \angle 0^\circ$	Slack bus
2	0.5	-	1.04 pu	PV bus
3	-1.0	0.5	-	PQ bus
4	0.3	-0.1	-	PQ bus

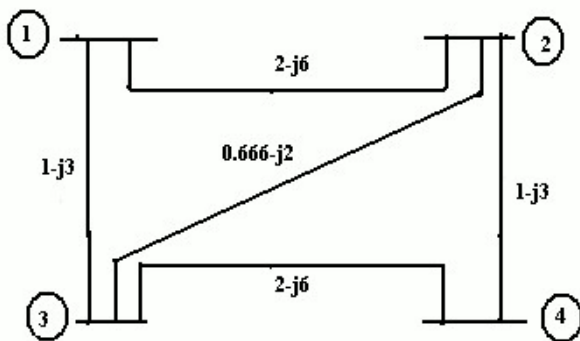

3

The Figure shows the one line diagram of a simple 3 bus system with generation at buses 1 and 3. Line impedances are marked in p.u on a 100 MVA base. Determine the bus voltages at the end of second iteration using Gauss seidal method (13)

CO 2

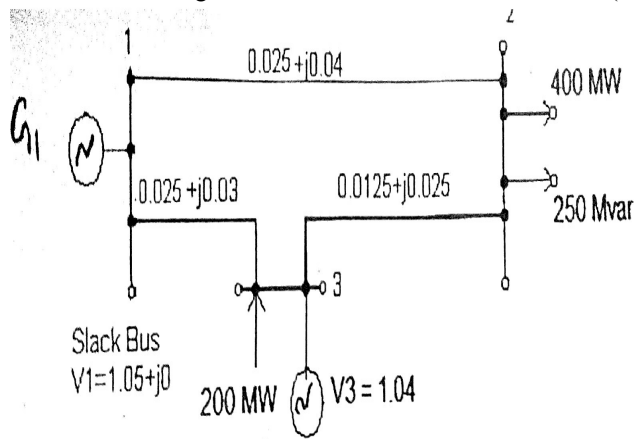

BT-3

Apply

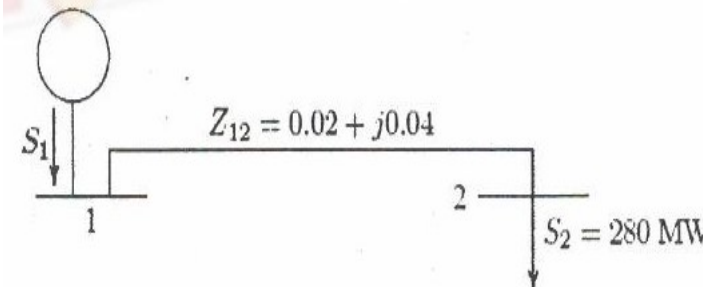
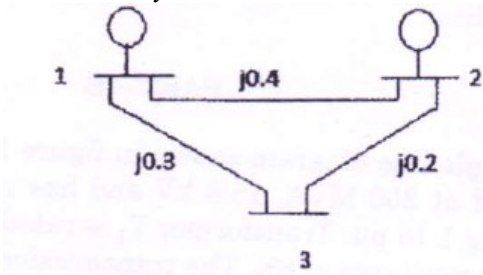

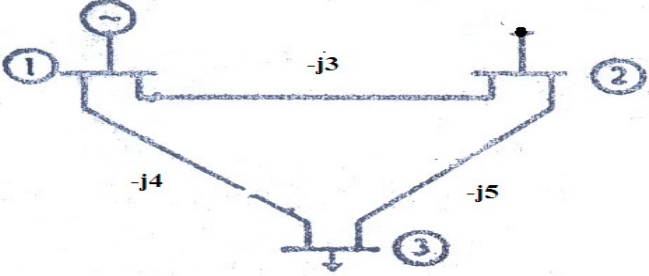
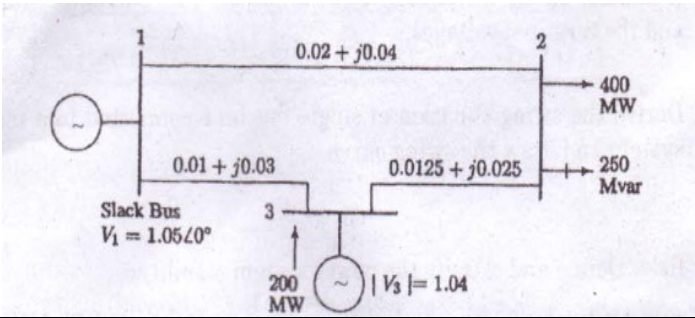
4	<p>In the power system network shown in figure, bus 1 is slack bus with $V_1 = 1.0 + j0.0$ per unit and bus 2 is a load bus with $S_2 = 280\text{MW} = j60\text{MVAR}$. The line impedance on a base of 100MVA is $Z = 0.02 + j0.04$ per unit. Using Gauss – Seidal method, give V_2. Use an initial estimate of $V_2^{(0)} = 1.0 + j0.0$ and perform four iterations. Also find S_1 and the real, reactive power loss in the line, assuming that the bus voltages have converged. (13)</p> 	CO 2	BT-6	Create																																				
5	<p>The system data for a load flow problem are given in table.</p> <p>(i) Compute Y bus.</p> <p>(ii) Solve bus voltages at the end of first iteration by G-S method by taking $\alpha = 1.6$. (16)</p> <table border="1" data-bbox="305 751 639 932"> <thead> <tr> <th>Line no</th> <th>Bus code</th> <th>Admittance in pu</th> </tr> </thead> <tbody> <tr> <td>1</td> <td>1-2</td> <td>2-j8</td> </tr> <tr> <td>2</td> <td>1-3</td> <td>1-j4</td> </tr> <tr> <td>3</td> <td>2-3</td> <td>0.6-j2.6</td> </tr> </tbody> </table>	Line no	Bus code	Admittance in pu	1	1-2	2-j8	2	1-3	1-j4	3	2-3	0.6-j2.6	CO 2	BT-3	Apply																								
Line no	Bus code	Admittance in pu																																						
1	1-2	2-j8																																						
2	1-3	1-j4																																						
3	2-3	0.6-j2.6																																						
6	<p>For the system show in figure determine the voltages at the end of first iteration by Gauss seidel methods. Assume base MVA as 100</p>  <table border="1" data-bbox="297 1365 950 1648"> <thead> <tr> <th rowspan="2">Bus No.</th> <th rowspan="2">Voltage</th> <th colspan="2">Generator</th> <th colspan="2">Load</th> <th rowspan="2">Q_{\min} MVAR</th> <th rowspan="2">Q_{\max} MVAR</th> </tr> <tr> <th>P</th> <th>Q</th> <th>P</th> <th>Q</th> </tr> </thead> <tbody> <tr> <td>1</td> <td>1.05 $\angle 0^\circ$ p.u.</td> <td>-</td> <td>-</td> <td>-</td> <td>-</td> <td>-</td> <td>-</td> </tr> <tr> <td>2</td> <td>1.02 p.u.</td> <td>0.3 p.u.</td> <td>-</td> <td>-</td> <td>-</td> <td>-10</td> <td>100</td> </tr> <tr> <td>3</td> <td>-</td> <td>-</td> <td>-</td> <td>0.4 p.u.</td> <td>0.2 p.u.</td> <td>-</td> <td>-</td> </tr> </tbody> </table>	Bus No.	Voltage	Generator		Load		Q_{\min} MVAR	Q_{\max} MVAR	P	Q	P	Q	1	1.05 $\angle 0^\circ$ p.u.	-	-	-	-	-	-	2	1.02 p.u.	0.3 p.u.	-	-	-	-10	100	3	-	-	-	0.4 p.u.	0.2 p.u.	-	-	CO 2	BT-4	Analyze
Bus No.	Voltage			Generator		Load				Q_{\min} MVAR	Q_{\max} MVAR																													
		P	Q	P	Q																																			
1	1.05 $\angle 0^\circ$ p.u.	-	-	-	-	-	-																																	
2	1.02 p.u.	0.3 p.u.	-	-	-	-10	100																																	
3	-	-	-	0.4 p.u.	0.2 p.u.	-	-																																	

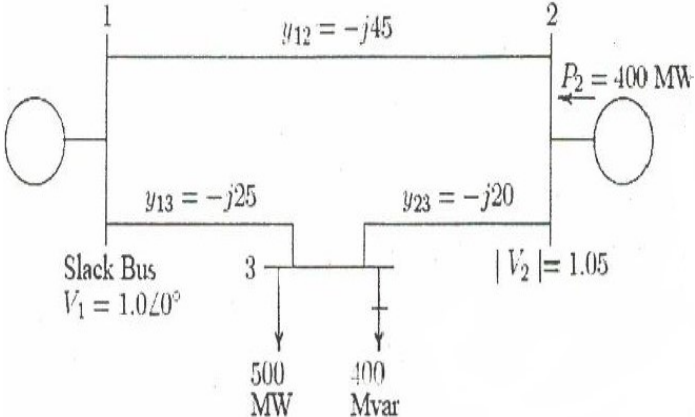
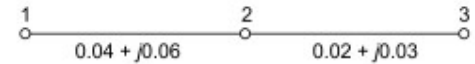
7	<p>A three bus power system is shown in figure. the relevant per unit line admittance on 100MVA base are indicated on the diagram and bus data are given in table. form Y_{bus} and Give the voltage at bus 2 and bus 3 after first iteration using gauss seidal method. Take the acceleration factor $\alpha=1.6$. (13)</p>  <table border="1" data-bbox="277 573 967 947"> <thead> <tr> <th rowspan="2">Bus Number</th> <th rowspan="2">Type</th> <th colspan="2">Generation</th> <th colspan="2">Load</th> <th colspan="2">Bus voltage</th> </tr> <tr> <th>P_G (MW)</th> <th>Q_G (MVAR)</th> <th>P_G (MW)</th> <th>Q_G (MVAR)</th> <th>V(p.u)</th> <th>δ deg</th> </tr> </thead> <tbody> <tr> <td>1</td> <td>Slack</td> <td></td> <td>-</td> <td>0</td> <td>0</td> <td>1.02</td> <td>0</td> </tr> <tr> <td>2</td> <td>PQ</td> <td>25</td> <td>15</td> <td>50</td> <td>25</td> <td>-</td> <td>-</td> </tr> <tr> <td>3</td> <td>PQ</td> <td>0</td> <td>0</td> <td>60</td> <td>30</td> <td>-</td> <td>-</td> </tr> </tbody> </table>	Bus Number	Type	Generation		Load		Bus voltage		P_G (MW)	Q_G (MVAR)	P_G (MW)	Q_G (MVAR)	V(p.u)	δ deg	1	Slack		-	0	0	1.02	0	2	PQ	25	15	50	25	-	-	3	PQ	0	0	60	30	-	-	CO 2	BT-5	Evaluate
Bus Number	Type			Generation		Load		Bus voltage																																		
		P_G (MW)	Q_G (MVAR)	P_G (MW)	Q_G (MVAR)	V(p.u)	δ deg																																			
1	Slack		-	0	0	1.02	0																																			
2	PQ	25	15	50	25	-	-																																			
3	PQ	0	0	60	30	-	-																																			
8	<p>Explain the types of buses and derive the power flow equations in load flow analysis. (13)</p>	CO 2	BT-1	Remember																																						
9	<p>Evaluate the Jacobian elements for the 3-bus system shown in figure. All the impedance in this figure are mentioned in p,u</p> 	CO 2	BT-2	Understand																																						
10	<p>Solve necessary expressions for the off-diagonal and diagonal elements of the sub- matrices J_1 , J_2 , J_3 and J_4 for carrying out a load flow study on power system by using N-R method in Polar form. (13)</p>	CO 2	BT-1	Remember																																						
11	<p>The converged load flow solution is available how do you determine the slack bus complex power injection and system total loss? (13)</p>	CO 2	BT-1	Remember																																						

12	<p>Figure shows the one line diagram of a simple three bus power system with generation at buses at 1 and 2. the voltage at bus 1 is $V=1+j0.0$ V per unit. Voltage magnitude at bus 2 is fixed at 1.05 p.u. with a real power generation of 400 MW. A Load consisting of 500MW and 400 MVAR base. For the purpose of hand calculation, line resistance and line charging susceptances are neglected</p>  <p>Using Newton-Raphson method, start with the initial estimates of $V_2^0=1.05+j0.0$ and $V_3^0=1.05+j0.0$, and keeping $V_2 =1.05$ p.u., examine the phasor values v_2 and v_3. perform two iterations. (13)</p>	CO 2	BT-5	Evaluate
13	Derive N-R method of load flow algorithm and explain the implementation of this algorithm with the flowchart. (13)	CO 2	BT-2	Understand
14	(i) Derive the static load flow equations of n-bus system. (7) (ii) Compare GSLF, NRLF Methods. (6)	CO 2	BT-4	Analyze
15	Formulate the load flow equations using Ybus matrix and Explain the computational procedure for load flow by Newton Raphson method.	CO 2	BT-5	Evaluate
16	<p>For the network shown in Fig, obtain the complex bus bar voltage at bus 2 at the end of the first iteration. Use the GS method. Line impedances shown in Fig are in pu. Given Bus 1 is slack bus with $V_1=1.0+j0$, $P_2+jQ_2=-5.96+j1.46$ $V_3=1.02$</p> 	CO 2	BT-2	Understand
17	<p>For the system of Fig. find the voltage at the receiving bus at the end of the first iteration. Load is $2+j0.8$ pu. Voltage at the sending end (slack) is $1+j0$ pu. Line admittance is $1.0-j4.0$ pu. Transformer reactance is $j0.4$ pu. Off-nominal turns ratio is $1/1.04$. Use the GS technique. Assume $VR=1\angle 0^\circ$</p> 	CO 2	BT-4	Analyze
PART - C				
1	With a neat flow chart explain the computational procedure for load flow solution using gauss seidal method when the system contain all types of buses (15)	CO 2	BT-6	Create

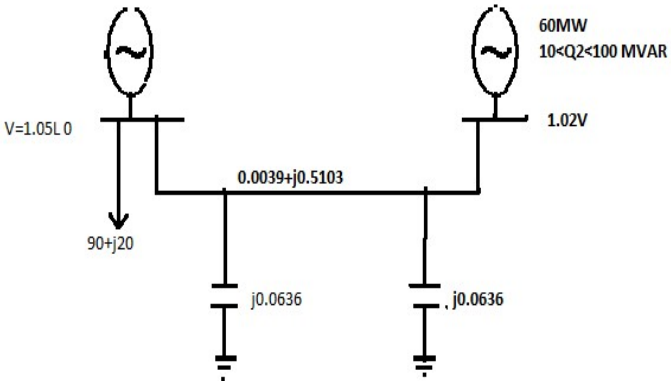
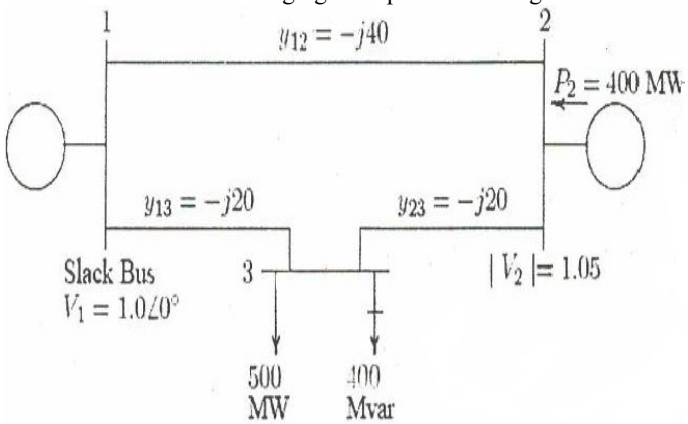
2	<p>Using Gauss Seidal method examines bus voltages for the fig shown. Take base MVA as 100, $\alpha=1.1$. (15)</p> 	CO 2	BT-3	Apply
3	<p>Figure shows the one line diagram of a simple three bus power system with generation at buses at 1 and 2. the voltage at bus 1 is $V=1+j0.0$ V per unit. Voltage magnitude at bus 2 is fixed at 1.05 p.u. with a real power generation of 400 MW. A Load consisting of 500MW and 400 MVAR base. For the purpose of hand calculation, line resistance and line charging susceptances are neglected</p>  <p>Using Newton-Raphson method, start with the initial estimates of $V_2^0=1.05+j0.0$ and $V_3^0=1.05+j0.0$, and keeping $V_2 =1.05$ p.u., examine the phasor values v_2 and v_3. perform two iterations. (15)</p>	CO 2	BT-5	Evaluate
4	<p>With a neat flow chart explain the computational procedure for load flow solving using Newton Raphson iterative method when the system contain all types of buses (15)</p>	CO 2	BT-5	Evaluate

5

Consider the three-bus system of Fig. The pu line reactances are indicated on the figure; the line resistances are negligible. The magnitude of all the three-bus voltages are specified to be 1.0 pu. The bus powers are specified in the following table below:

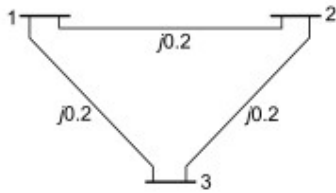

Bus	Real demand	Reactive demand	Real generation	Reactive generation
1.	$P_{D1} = 1.0$	$Q_{D1} = 0.6$	$P_{G1} = ?$	Q_{G1} (unspecified)
2.	$P_{D2} = 0$	$Q_{D2} = 0.0$	$P_{G2} = 1.4$	Q_{G2} (unspecified)
3.	$P_{D3} = 1.0$	$Q_{D3} = 1.0$	$P_{G3} = 0$	Q_{G3} (unspecified)

Carry out the complete approximate load flow solution. Mark generations, load demands and line flows on the one-line diagram.

CO 2

BT-5

Evaluate

UNIT III SYMMETRICAL FAULT ANALYSIS

Assumptions in short circuit analysis - Symmetrical short circuit analysis using Thevenin's theorem - Bus Impedance matrix building algorithm (without mutual coupling) - Symmetrical fault analysis through bus impedance matrix - Post fault bus voltages - Fault level - Current limiting reactors.

PART - A

Q.No	Questions	Course Outcome	BT Level	Competence
1	Write the ways of adding an impedance to an existing system to modify bus impedance matrix	CO 3	BT-4	Analyze
2	Define short circuit capacity of power system	CO 3	BT-1	Remember
3	Show the oscillation of short circuit current when an unloaded generator is subjected to a symmetrical fault clearly marking sub-transient, transient and steady state regions	CO 3	BT-3	Apply
4	Discuss the prefault currents are usually neglected in fault computation?	CO 3	BT-4	Analyze
5	What is meant by fault calculations	CO 3	BT-2	Understand
6	What is meant by symmetrical fault	CO 3	BT-5	Evaluate
7	Distinguish between symmetrical and unsymmetrical short circuits.	CO 3	BT-5	Evaluate
8	Define bolted fault?	CO 3	BT-1	Remember
9	The Z bus method is very suitable for fault studies on large system infer?	CO 3	BT-4	Analyze
10	Summarize two approximations made in short circuit studies	CO 3	BT-1	Remember
11	How do Short circuits occur in power system and Summarize two objective of Short circuit analysis?	CO 3	BT-3	Apply
12	Discover the main differences in representation of power system for load flow and short circuit studies.	CO 3	BT-2	Understand
13	Compose, What is meant by doubling effect?	CO 3	BT-2	Understand
14	Explain the need for fault analysis in power system?	CO 3	BT-6	Create
15	Explain the sub transient reactance and transient reactance?	CO 3	BT-1	Remember
16	Summarize the reason for transients during short circuit?	CO 3	BT-6	Create
17	State and explain symmetrical fault	CO 3	BT-3	Apply
18	Define synchronous reactance, transient reactance, sub transient reactance	CO 3	BT-1	Remember
19	Define fault level.	CO 3	BT-1	Remember
20	Summarize the applications of short circuit analysis	CO 3	BT-2	Understand
21	Can feeder reactors permit the use of circuit breakers of lower ratings ?	CO 3	BT-1	Remember
22	Will the value of short-circuit current change if we take different base kVAs'? Explain your answer.	CO 3	BT-6	Create
23	What is the advantage of expressing reactances in percentage values	CO 3	BT-3	Apply
24	Explain the harmful effects of short-circuit fault on the power	CO 3	BT-1	Remember

PART - B

1	Explain the step by step procedure for systematic fault analysis for a three phase fault using bus impedance matrix. (13)	CO 3	BT-1	Remember
2	A 3 phases 5 MVA, 6.6 kV alternator with a reactance of 8% is connected to a feeder series impedance (0.12+j0.48) ohm/phase/km through a step up transformer. The transformer rated at 3 MVA, 6.6 kV/33kV and has reactance of 5%. Determine the fault current supplied by the generator operating under no load with a voltage of 6.9 kV, when a 3 phases symmetrical fault occurs at a point 15km along the feeder. (13)	CO 3	BT-2	Understand

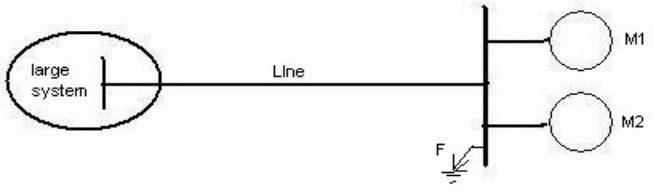
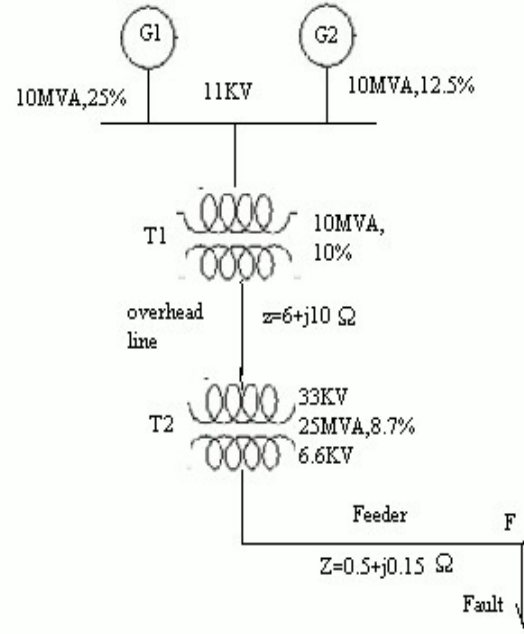
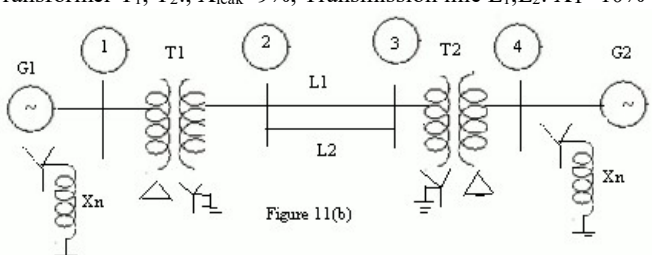
3	<p>Two synchronous motor are connected to the bus of large system through a short transmission line shown in fig. The rating of the various components is given.</p> <p>MOTOR (each): 1 MVA, 440V, 0.1 p.u.</p> <p>Transient reactance line: 0.05Ω (reactance)</p> <p>Large system: Short circuit MVA at its bus at 440V is 8</p> <p>When the motor are operating at 400V, examine the short circuit current (symmetrical) fed into a three phase fault at motor bus. (13)</p> 	CO 3	BT-5	Evaluate
4	<p>Explain the step by step procedure to find the fault current of three phase symmetrical fault by using thevenin's theorem. (13)</p>	CO 3	BT-1	Remember
5	<p>For the radial network shown in figure , a 3 phase fault occurs at point F. examine the fault current. (13)</p> 	CO 3	BT-4	Analyze
6	<p>A symmetrical fault occurs on bus 4 of system shown in figure; examine the fault current, post fault voltages, line flows.</p> <p>Generator G_1, G_2 :100MVA,20KV,$X_1=15\%$.</p> <p>Transformer T_1, T_2;, $X_{leak}=9\%$, Transmission line L_1, L_2: $X_1=10\%$</p>  <p style="text-align: center;">Figure 11(b)</p> <p style="text-align: right;">(13)</p>	CO 3	BT-1	Remember

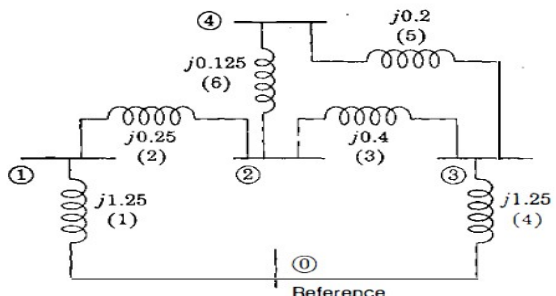
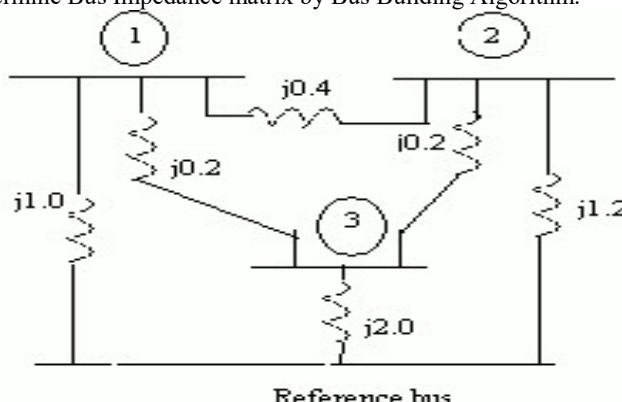
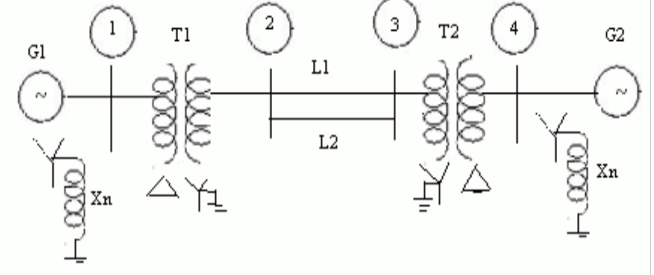
7	<p>Examine the bus impedance matrix using bus building algorithm for the given network.</p>  <p style="text-align: right;">(13)</p>	CO 3	BT-2	Understand
8	<p>Determine Bus Impedance matrix by Bus Building Algorithm.</p>  <p style="text-align: center;">Reference bus</p>	CO 3	BT-3	Apply
9	 <p>A symmetrical fault occurs on bus 4 of system through $Z_f=j0.14$ pu in figure. Using bus building algorithm, calculate the fault current, post fault voltages, line flows.</p> <p>$G_1, G_2: 100\text{MVA}, 20\text{kV}, X^+=15\%$</p> <p>Transformer $T_1, T_2: X_{leak}=9\%$</p> <p>Transmission line $L_1, L_2, X^+=10\%$. (13)</p>	CO 3	BT-2	Understand
10	<p>A 3-phase 5MVA, 6.6 KV alternators with a reactance of 8% is connected to a feeder of series impedance $(0.12+j0.48)$ ohm/phase/Km through a step up transformer. The transformer is rated at 3 MVA, 6.6 KV/33KV and has a reactance of 5%. Calculate the fault current supplied by the generator operating under no load with a voltage of 6.9 KV when a three phase symmetrical fault occurs at a point 15Km along the feeder.(13)</p>	CO 3	BT-3	Apply

11	<p>Two generator are connected in parallel to the low voltage side of a 3Φ delta star transformer as shown in figure. generator 1 is rated 60,000 KVA, 11 KV.generator 2 is rated 30,000 KVA, 11KV.each generator has a sub transient reactance of $X_d''=25\%$.the transformer is rated 90,000 KVA at 11 KV-delta/66KV star with a reactance of 10%.before a fault occurred, the voltage on the HT side of the transformer is 63KV.the transformer is unloaded and there is no circulating current between the generators. Calculate the sub transient current in each generator when a three phase fault occurs on the HT side of the transformer. (13)</p>	CO 3	BT-5	Evaluate
12	<p>A generator transformer unit is connected to a line circuit breaker.the unit rating are: Generator: 10MVA, 6.6KV; $X_d''=0.1$ p.u, $X_d'=0.2$ p.u and $X_d=0.8$ p.u Transformer:10mva,6.9/33KV,$X=0.08$ p.u, The system is operating on no load at a line voltage of 30 KV, when a 3Φ fault occurs on the line jest beyond the circuit breaker. Solve (i)The initial symmetrical rms current in the breaker. (ii) The maximum possible dc offset current in the breaker. (iii)the momentary current rating of the breaker (iv) the current to be interrupted by the breaker and the interrupting KVA (V) The sustained short circuit current in the breaker. (13)</p>	CO 3	BT-4	Analyze
13	<p>A 25,000 KVA, 13.8 kV generator with $X_d'' = 15\%$ is connected through a transformer to a bus which supplies four identical motors as shown in Fig. The sub transient reactance X_d'' of each motor is 20% on a base of 5000 KVA, 6.9 kV. The three-phase rating of the transformer is 25,000 KVA, 13.8/6.9 kV, with a leakage reactance of 10%. The bus voltage at the motors is 6.9 kV when a three-phase fault occurs at point p. for the fault specified, Point out (i) The sub transient current in the fault (ii) the sub transient current in breaker A and (iii) the symmetrical short-circuit interrupting current in the fault and in breaker A. (13)</p>	CO 3	BT-4	Analyze
14	<p>With help of detailed flow chart, explain how symmetrical fault can be analysed using Z_{bus} (13)</p>	CO 3	BT-1	Remember
15	<p>Starting from Z BUS for a partial network describe step - by - step how you will obtain the Z BUS for a modified network when a new line is to be added to a bus in the existing network.</p>	CO 3	BT-3	Apply

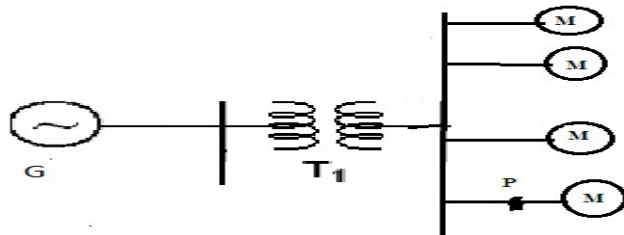
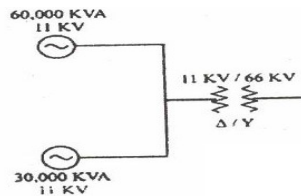

16	A 3-phase, 30 MVA, 33 kV alternator has internal reactance of 4% and negligible resistance. Find the external reactance per phase to be connected in series with the alternator so that steady current on short circuit does not exceed 10 times the full load current.	CO 3	BT-5	Evaluate
17	A generating station has four bus-bar sections. Each section is connected to tie-bar through 20% reactors rated at 200 MVA. Generators of total capacity 100 MVA and 20% reactance are connected to each busbar section. Calculate the MVA fed to a fault under short-circuit condition one of the bus-bars.	CO 3	BT-4	Analyze

PART - C

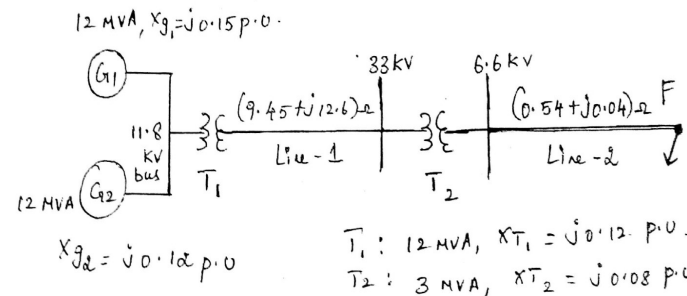
1	The plant capacity of a 3-phase generating station consists of two 8 MVA generators of reactance 14.5% each and one 4 MVA generator of reactance 9.5%. These are connected to a common bus-bar from which loads are taken through a number of 3 MVA step-up transformers each having 4% reactance. Determine the MVA rating of the circuit breakers on (i) L.V. side and (ii) H.V. side. Reactances given are based on the MVA of each equipment.	CO 3	BT-4	Analyze
2	A 3 phase transmission line operating at 33kV and having resistance of 5Ω and reactance of 20Ω is connected to the generating station through 15,000 KVA step up transformers. Connected to the bus bar are two alternators one of 10,000KVA with 10% reactance and another of 5000 KVA with 7.5% reactance. Draw the single line diagram and calculate the short circuit KVA for symmetrical fault between phases at the load end of the transmission line (15)	CO 3	BT-5	Evaluate
3	(i) Write a short note on fault current in synchronous machine (10) (ii) What are the assumptions made in fault analysis (5)	CO 3	BT-5	Evaluate
4	For the radial network shown in figure 3 phase fault occurs at point F. Determine the fault current and the line voltage at 11.8 kV bus under fault condition 	CO 3	BT-3	Apply
5	A 3-phase transmission line operating at 33 kV and having a resistance of 5Ω and reactance of 20Ω is connected to the generating station through 15,000 kVA step-up transformer. Connected to the bus-bar are two alternators, one of 10,000 kVA with 10% reactance and another of 5000 kVA with 7.5% reactance. Calculate the short-circuit kVA fed to the symmetrical fault between phases if it occurs (i) at the load end of transmission line (ii) at the high voltage terminals of the transformer	CO 3	BT-5	Evaluate

UNIT IV UNSYMMETRICAL FAULT ANALYSIS

Symmetrical components - Sequence impedances - Sequence networks - Analysis of unsymmetrical faults at generator terminals: LG, LL and LLG - unsymmetrical fault occurring at any point in a power system

PART - A

Q.No	Questions	Course Outcome	BT Level	Competence
1	Name the faults which are having all three equal sequence current and which do not have zero sequence current	CO 4	BT-1	Remember
2	Why the neutral grounding impedance Z_n appears as $3Z_n$ in zero sequence equivalent circuit	CO 4	BT-2	Understand
3	Point out the sequence network diagram for line to line fault with fault impedance	CO 4	BT-5	Evaluate
4	Evaluate the sequence network diagram for line to ground with fault impedance	CO 4	BT-3	Apply
5	Explain the significance of sub transient reactance and transient reactance in short circuit studies	CO 4	BT-2	Understand
6	Write boundary conditions for single line to ground faults	CO 4	BT-1	Remember
7	Describe the symmetrical component of phase 'a' in terms of the current	CO 4	BT-4	Analyze
8	Describe the equation for sub transient and transient internal voltage	CO 4	BT-3	Apply
9	Define doubling effect and DC off-set current	CO 4	BT-1	Remember
10	Summarize difference between sub transient and transient reactance			
11	Explain the features of zero sequence current?	CO 4	BT-3	Apply
12	Discuss the symmetrical components of three phase system	CO 4	BT-5	Evaluate
13	Define negative sequence and zero sequence components	CO 4	BT-1	Remember
14	Define short circuit capacity	CO 4	BT-1	Remember
15	Discover the symmetrical components V_{a1} , V_{a2} and V_{a0} in terms of unbalanced vectors V_a , V_b and V_c .	CO 4	BT-4	Analyze
16	Write down the equation to determine symmetrical currents for unbalanced current	CO 4	BT-6	Create
17	What are symmetrical components	CO 4	BT-2	Understand
18	Demonstrate the zero sequence network diagram of a delta-delta connected transformer.	CO 4	BT-4	Analyze
19	In which fault, the negative and zero sequence currents are absent?	CO 4	BT-6	Create
20	Develop the connection of sequence networks for line-to-line fault without fault impedance.	CO 4	BT-2	Understand
21	Why do we prefer to analyse unsymmetrical faults by symmetrical components method?	CO 4	BT-6	Create
22	Express unbalanced phase currents in a 3- ϕ system in terms of symmetrical component	CO 4	BT-2	Understand
23	Why is 3- ϕ symmetrical fault more severe than a 3- ϕ unsymmetrical fault?	CO 4	BT-4	Analyze
24	In a 3- ϕ system, it has been found that negative sequence components and zero sequence components are absent. What do you conclude from it?	CO 4	BT-6	Create

PART - B

1	Examine the sequence impedance of synchronous machine, transmission lines and Star connected loads. (13)	CO 4	BT-5	Evaluate
2	Label the transformer zero sequence equivalent circuits for the various winding connections and delta connected load (13)	CO 4	BT-1	Remember
3	A 25MVA, 11KV, three phase generator has a sub transient reactance of 20%. The generator supplies two motors over a transmission line with transformers at both ends as shown in one line diagram a of figure. The motors have rated inputs of 15 and 7.5 MVA both 10KV with 25% sub transient reactance. The three phase transformers are rated 30MVA, 10.8/121KV, and connection delta-star with leakage reactance of 10% each. The series reactance of the line is 100 ohms. Label the positive and negative sequence networks of the system with reactance marked in per unit. (13)	CO 4	BT-6	Create
4	Examine the sequence network for a double line to ground (LLG) fault. (13)	CO 4	BT-2	Understand
5	A salient pole generator without dampers is rated 20 MVA, 13.6 KV and has direct axis sub – transient reactance of 0.2 per unit. The negative and zero sequence reactance's are, respectively, 0.35 and 0.1 per unit. The neutral of the generator is solidly grounded. With the generator operating unloaded at rated voltage with $E_{an}=1.0 \angle 0^\circ$ per unit, a single line to ground fault occurs at the machine terminals, which then have per -unit voltage to ground, $V_a = 0; V_b = 1.013 \angle -102.25^\circ;$ $V_c=1.013 \angle 102.25^\circ$ Give the sub transient current in the generator and the line to line voltage for sub transient conditions due to the fault. (13)	CO 4	BT-3	Apply
6	Discuss the expression for fault current in single line to ground fault on unloaded generator. Draw an equivalent network showing the inter connection of networks to simulate single line to ground fault (13)	CO 4	BT-1	Remember
7	Show the expression for fault current in double line to ground fault on unloaded generator. Draw an equivalent network showing the inter connection of networks to simulate double line to ground fault (13)	CO 4	BT-1	Remember
8	Show the expression for fault current in line to line fault on unloaded generator. Draw an equivalent network showing the inter connection of networks to simulate double line to line fault. (13)	CO 4	BT-2	Understand
9	A 25 MVA,13.2KV alternator with solidly grounded neutral has a sub transient reactance os 0.25.the negative and zero sequence reactance are 0.35 and 0.01 p.u .respectively if a double line to ground fault occurs at the terminals of the alternator. Point out the fault current and line to line voltage at the fault. (13)	CO 4	BT-3	Apply
10	Point out the expression for fault current for a line to line fault taken place through impedance Z_b in a power system. (13)	CO 4	BT-2	Understand

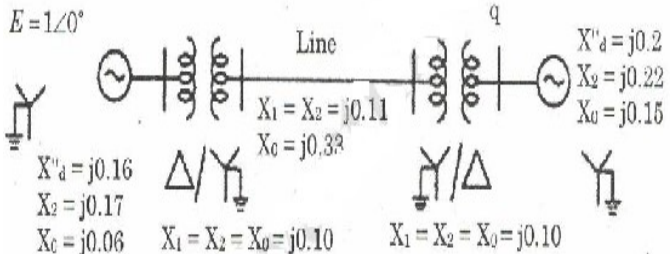
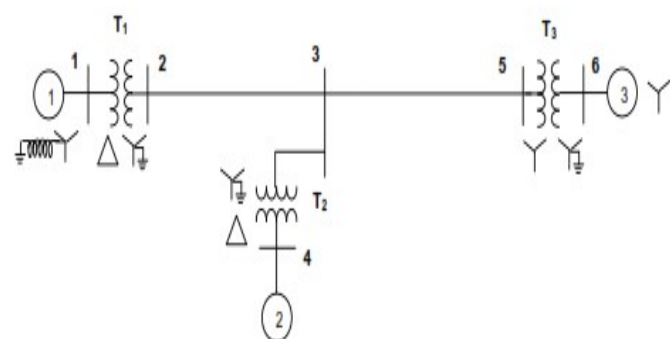
11	<p>A Double Line to Ground fault occurs on line b and c at point F in the system of figure . Point out the sub transient current in phase c of the machine 1.assuming pre fault current to be zero. Both machine are rated 1200 KVA,600 V with reactance of $X''=X_2=10\%$ AND $X_0=5\%$.each tree phase transformer is rated 1200KVA,600V-delta/300V-star with leakage reactance of 5%.the reactance of the transmission line are $X_1=X_2=20\%$ and $X_0=40\%$ on the base of 1200 KVA,3300V.the reactance of the neutral of the grounding reactors are 5% on the KVA base of the machines. (13)</p>	CO 4	BT-3	Apply
12	<p>. Calculate the sub transient current in each phase for a dead short circuit on the one phase to ground at bus 'q' for the system shown in figure below. (13)</p>  <p>The diagram shows a power system with a generator on the left, a transformer, a transmission line, and another transformer. The generator has $E = 1 \angle 0^\circ$. The transformer has $X_1 = X_2 = j0.11$ and $X_0 = j0.33$. The transmission line has $X_1 = X_2 = j0.11$ and $X_0 = j0.33$. The second transformer has $X_1 = X_2 = j0.10$ and $X_0 = j0.10$. The generator's sub-transient reactances are $X''_d = j0.16$, $X_2 = j0.17$, and $X_0 = j0.06$. The system is grounded through reactors at the generator and transformer locations.</p>	CO 4	BT-4	Analyze
13	<p>. The one-line diagram of a power system is shown below. (16)</p>  <p>The diagram shows a power system with three generators (1, 2, 3) and three transformers (T1, T2, T3) connected by transmission lines. Bus 1 is connected to bus 2 via transformer T1. Bus 2 is connected to bus 3 via a transmission line. Bus 3 is connected to bus 5 via a transmission line. Bus 5 is connected to bus 6 via transformer T3. Bus 6 is connected to bus 4 via transformer T2. Bus 4 is connected to bus 2 via a transmission line. The system is grounded through reactors at bus 1 and bus 6.</p> <p>The following are the p.u. reactances of different elements on a common base</p> <p>Generator 1: $X_{g0} = 0.075$; $X_n = 0.075$; $X_1 = X_2 = 0.25$ Generator 2: $X_{g0} = 0.15$; $X_n = 0.15$; $X_1 = X_2 = 0.2$ Generator 3: $X_{g0} = 0.072$; $X_1 = X_2 = 0.15$ Transformer 1: $X_0 = X_1 = X_2 = 0.12$ Transformer 2: $X_0 = X_1 = X_2 = 0.24$ Transformer 3: $X_0 = X_1 = X_2 = 0.1276$ Transmission line 2 – 3 $X_0 = 0.5671$; $X_1 = X_2 = 0.18$ Transmission line 3 – 5 $X_0 = 0.4764$; $X_1 = X_2 = 0.12$ Prepare the three sequence networks and determine reactances $Z_{bus0}, Z_{bus1}, Z_{bus2}$</p>	CO 4	BT-4	Analyze

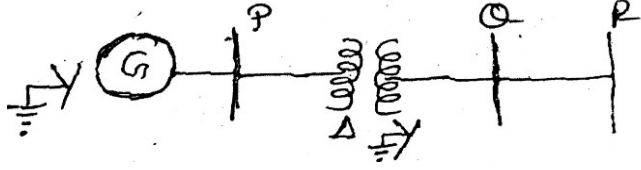
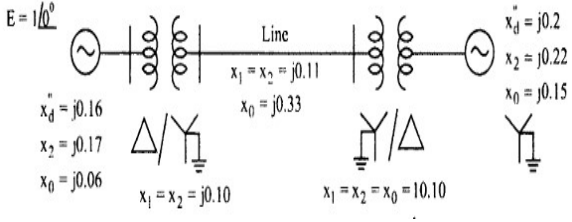
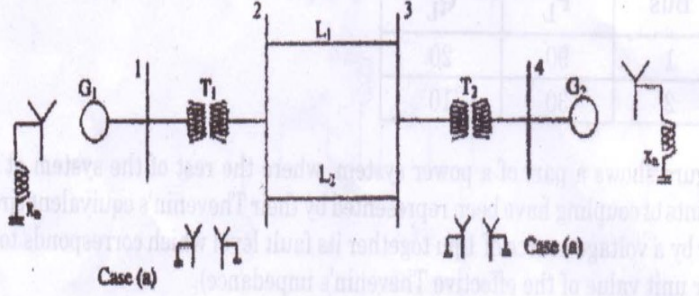
14	<p>A 50 Hz 50 MVA, 13.2 kV star grounded alternator is connected to a line through a Δ-Y transformer as shown in figure. The positive, negative, zero sequence impedance of the alternator are $j0.1, j0.1, j0.05$ respectively. The transformer rated at 13.2 kV Δ / 120 kV Y, 50 Hz with Y solidly grounded has the sequence impedance $X''=X_2=X_0=j0.1$ p.u. The line impedance between Q and R are $X_1''=j0.03, X_2=j0.03, X_0=j0.09$. Assuming that the fault to be taken place at Q, determine the subtransient fault for a (i) 3 phase fault (ii) L-G fault (iii) L-L-G fault. Draw the connection diagram for the sequence diagram in each fault (15)</p> 	CO 4	BT-5	Evaluate
15	Prove that neutral current can flow only if zero-sequence currents are present	CO 4	BT-4	Analyze
16	<p>Calculate the subtransient fault current in each phase for a dead short circuit on one phase to ground at bus 'q' for the system shown in Fig.</p> 	CO 4	BT-3	Apply
17	<p>A 20 MVA, 6.6 kV star connected generator has positive, negative and zero sequence reactances of 30%, 25% and 7% respectively. A reactor with 5% reactance based on the rating of the generator is placed in the neutral to ground connection. A line-to-line fault occurs at the terminals of the generator when it is operating at rated voltage. Find the initial symmetrical line-to-ground r.m.s fault current. Find also the line-to-line voltage.</p>	CO 4	BT-5	Evaluate
PART - C				
1	 <p>It is proposed to conduct fault analysis on two alternative configuration of the 4 bus system</p> <p>$G_1, G_2: 100\text{MVA}, 200\text{kV}. X^+ = X^- = X_d'' = 20\%, X_0 = 4\%, X_n = 5\%$</p> <p>$T_1, T_2: 100\text{MVA}, 20\text{kV}/345\text{kV}, X_{\text{leak}} = 8\%$</p> <p>$L_1, L_2: X^+ = X^- = 15\%; X_0 = 50\%$ on a base of 100 MVA</p> <p>For a three phase to ground (solid) fault at bus 4, determine the fault current and MVA at faulted bus, post fault bus voltages, fault current distribution in different elements of the network using Thevenine equivalent circuit. Draw a single line diagram showing the above results</p>	CO 4	BT-5	Evaluate

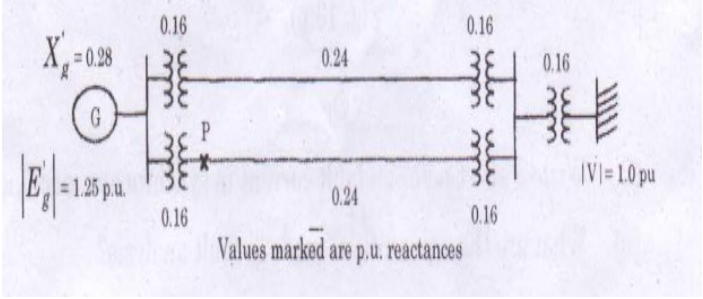
2	<p>In the power system shown in figure three phase fault occurs at point P and the faulty line was opened a little late. Find the power output equations for the pre-fault during fault and post fault calculation (15)</p> 	CO 4	BT-4	Analyze
3	<p>Explain the concept of symmetrical component is used short circuit studies in the power system (15)</p>	CO 4	BT-3	Apply
4	<p>Derive the expression for fault current in double line to ground fault on unloaded generators. Draw the equivalent network showing the interconnection of networks to simulate double line to ground fault (15)</p>	CO 4	BT-6	Create
5	<p>A balanced three phase load with an impedance of $(6-j8)$ ohm per phase, connected in star is having in parallel a delta connected capacitor bank with each phase reactance of 27 ohm. The star point is connected to ground through an impedance of $0 + j5$ ohm. Calculate the sequence impedance of the load.</p>	CO 4	BT-3	Apply

UNIT V -STABILITY ANALYSIS

Classification of power system stability – Rotor angle stability - Swing equation - Swing curve - Power-Angle equation - Equal area criterion - Critical clearing angle and time - Classical step-by-step solution of the swing equation – modified Euler method.

PART - A

Q.No	Questions	Course Outcome	BT Level	Competence
1	A four pole,60HZ synchronous generator has a rating of 200MVA,0.8 power factor lagging. the moment of inertia of the rotor is 45100 kg-m ² .formulate M and H	CO 5	BT-6	Create
2	Define stability.	CO 5	BT-1	Remember
3	Infer the significance of critical clearing time	CO 5	BT-4	Analyze
4	Discuss transient stability.	CO 5	BT-2	Understand
5	Summarize assumptions upon transient stability	CO 5	BT-4	Analyze
6	Define steady state stability limit?	CO 5	BT-1	Remember
7	How to improve the transient stability limit of the power system	CO 5	BT-3	Apply
8	Examine ,How to improve the transient stability limit of power system?	CO 5	BT-5	Evaluate
9	Classify steady state stability limit. Define them	CO 5	BT-2	Understand
10	Discover the machine problems seen in the stability study	CO 5	BT-3	Apply
11	Give the expression for swing equation. Explain each term along with their units.	CO 5	BT-1	Remember
12	Order are the assumptions made in solving swing equation?	CO 5	BT-2	Understand
13	Define swing curve. What is the use of swing curve?	CO 5	BT-1	Remember
14	Point out the control schemes included in stability control techniques?	CO 5	BT-3	Apply
15	What are coherent machines	CO 5	BT-4	Analyze
16	Point out equal area criterion	CO 5	BT-1	Remember
17	Give the expression for critical clearing time	CO 5	BT-6	Create
18	List the types of disturbances that may occur in a single machine	CO 5	BT-5	Evaluate
19	Define critical clearing angle.	CO 5	BT-1	Remember
20	List the assumptions made in multi machine stability studies	CO 5	BT-2	Understand
21	Define rotor angle stability. List out two categories of rotor angle stability.	CO 5	BT-1	Remember
22	What are the methods used to determine the control or small signal oscillation interaction?	CO 5	BT-6	Create
23	Discuss why? the use of automatic enclosing circuit breakers improve system stability.	CO 5	BT-5	Evaluate
24	On what basis can we conclude that synchronous generator goes out of stability?	CO 5	BT-4	Analyze

PART - B

1	Examine swing equation used for stability studies in power system. (13)	CO 5	BT-1	Remember
2	Describe the equal area criterion for transient stability analysis of a system (13)	CO 5	BT-4	Analyze
3	Interpret the computation algorithm for obtaining swing curves using modified Euler's method (13)	CO 5	BT-2	Understand

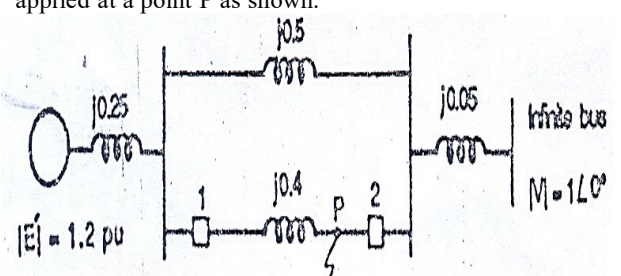
4	<p>. Examine a short note on</p> <p>i. Factors influencing transient stability (7)</p> <p>ii. Voltage collapse. (6)</p>	CO 5	BT-1	Remember
5	<p>. Given the system of figure below where a three phase fault is applied at a point P as shown.</p>  <p>Examine the critical clearing angle for clearing the fault with simultaneous opening of the breakers 1 and 2. The reactance vales of various components are indicated on the diagram. The generator is delivering 1.0 p.u power at the instant preceding the fault. The fault occurs at point P as shown in above figure. (13)</p>	CO 5	BT-2	Understand
6	<p>Examine the swing equation of a synchronous machine swinging against an infinite bus. Clearly state the assumption in deducing the swing equation. (13)</p>	CO 5	BT-6	Create
7	<p>(i) Derive Expression for critical clearing angle. (6)</p> <p>(ii) A 150 MVA generator – transformer unit having an overall reactance of 0.3 p.u. is delivering 150 MW to infinite bus bar over a double circuit 220 KV line having reactance per phase per circuit of 100 ohms. A 3 - phase fault occurs midway along one of the transmission lines. Give the maximum angle of swing that the generator may achieve before the fault is cleared without loss of stability. (7)</p>	CO 5	BT-4	Analyze
8	<p>A 50 Hz, 500 MVA, 400 KV generator (with transformer) is connected to a 400 KV infinite bus bar through an interconnector. The generator has $H = 2.5$ MJ/MVA, Voltage behind transient reactance of 450 KV and is loaded 460 MW. The transfer reactances between generator and bus bar under various conditions are :</p> <p>Prefault 0.5 Pu</p> <p>During Fault 1.0 Pu</p> <p>Post fault 0.75 Pu</p> <p>Calculate the swing curve using intervals of 0.05 sec and assuming that the fault is cleared at 0.15 sec. (13)</p>	CO 5	BT-5	Evaluate
9	<p>Explain the modified Euler method of analyzing multi machine power system for stability, with neat flow chart. (13)</p>	CO 5	BT-1	Remember
10	<p>A cylinder rotor generator delivers 0.5 pu power in the steady-state to an infinite bus through a transmission line of reactance 0.5 pu. The generator no-load voltage is 1.5 pu and the infinite bus voltage is 1 pu. The inertia constant of the generator is 5MW-s/MVA and the generator reactance is 1 pu. The critical clearing angle, in degrees, for a three-phase dead short circuit fault at the generator terminal is</p>	CO 5	BT-2	Understand

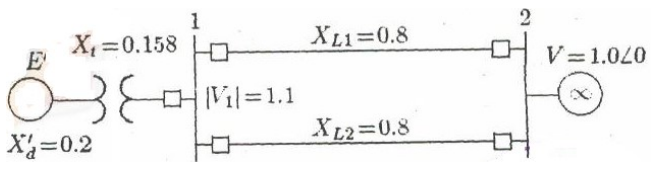
11	<p>In the power system shown in Fig three phase fault occurs at P and the faulty line was opened a little later. Find the power output equations for the pre-fault, during fault and post-fault condition.if delivering 1.0 p.u just before fault occurs, calculate δ_{cc}. (13)</p> 	CO 5	BT-3	Apply
12	<p>(i)A 60HZ synchronous generator has a transient reactance of 0.2 p.u and an inertia constant of 5.66MJ/MVA. the generator is connected to an infinite bus through a transformer and a double circuit transmission line, as shown in figure. resistance are neglected and reactance are expressed on a common MVA base and are marked on the diagram. the generator is delivering a real power of 0.77 p.u to bus bar 1. Voltage magnitude at bus 1 is 1.1 p.u.the infinite bus voltage $V=1.06\angle 0$ p.u. evaluate the generator excitation voltage and swing equation. (10)</p>  <p>(ii)A synchronous motor having a steady state stability limit of 200 MW is receiving 50 MW from the infinite bus bars. Find the maximum additional load that can be applied suddenly without causing instability. (3)</p>	CO 5	BT-3	Apply
13	<p>(i) A 2-pole 50 Hz, 11kV turbo alternator has a ratio of 100 MW, power factor 0.85 lagging. The rotor has a moment of inertia of $10,000 \text{ kgm}^2$. Evaluate H and M (4)</p> <p>(ii) A 50 HZ generator is delivering 50% of the power that it is capable of delivering through a transmission line to an infinite bus. A fault occurs that increases the reactance between the generator and the infinite bus to 500% of the value before the fault. When the fault is isolated, the maximum power that can be delivered is 75% of the original maximum value. Evaluate the critical clearing angle for the condition described (9)</p>	CO 5	BT-3	Apply
14	<p>(i)A generator is operating 50Hz,delivers 1.0 p.u power to an infinite through a transmission circuit in which resistance is ignored. A fault taken place reducing a maximum power transferable to 0.5 p.u. Before the fault, this power was 2.0 p.u and after the clearance of the fault it is 1.5p.u. By using equal area criterion ,determine the critical clearing angle (7)</p> <p>(ii) Discuss the method by which transient stability improved (6)</p>	CO 5	BT-1	Remember

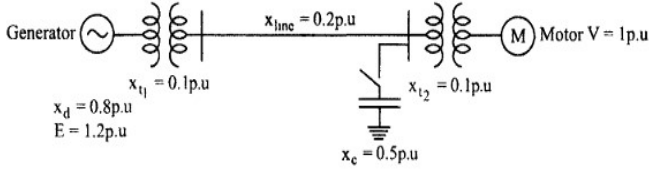
15	A generator rated 75 MVA is delivering 0.8 pu power to a motor through a transmission line of reactance $j 0.2$ p.u. The terminal voltage of the generator is 1.0 p.u and that of the motor is also 1.0p.u. Determine the generator e.m.f behind transient reactance. Find also the maximum power that can be transferred.	CO 5	BT-3	Apply
16	Power is supplied by a generator to a motor over a transmission line as shown in Fig. To the motor bus a capacitor of 0.8 pu reactance per phase is connected through a switch. Determine the steady state power limit with and without the capacitor in the circuit. 	CO 5	BT-4	Analyze
17	A four pole synchronous generator rated 110 MVA 12.5 KV, 50 HZ has an inertia constant of 5.5 MJ/MVA (i) Determine the stored energy in the rotor at synchronous speed. (ii) When the generator is supplying a load of 75 MW, the input is increased by 10 MW. Determine the rotor acceleration, neglecting losses. (iii) If the rotor acceleration in (ii) is maintained for 8 cycles, find the change in the torque angle and the rotor speed in rpm at the end of 8 cycles	CO 5	BT-3	Apply
PART - C				
1	(i) Define and classify the power system stability (7) (ii) A 4 pole 50Hz, 11kV turbo generator is rated 75MW and 0.86 power factor lagging. The machine rotor has moment of inertia of 9000Kg-m ² . Find the inertial constant in MJ/MVA and M constant or momentum in MJ/electrical degree (8)	CO 5	BT-3	Apply
2	Derive the swing equation of single machine connected to an infinite bus system and draw the swing curve (15)	CO 5	BT-4	Analyze
3	Explain the equal area criteria for the following applications (i) Sustained fault (ii) Fault with subsequent clearing (15)	CO 5	BT-4	Analyze

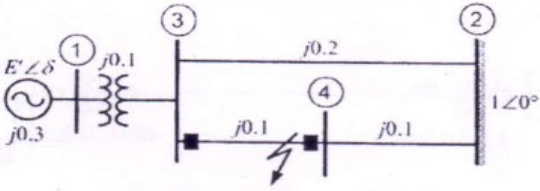
4	<p>The per unit system reactances that are converted to common base are shown in figure. Let us assume that the infinite bus voltage is 10. The generator is delivering 1.0 per unit real power at a lagging power factor of 0.93839 to the infinite bus. While the generator is operating in steady state a three phase bolted short circuit occurs in the transmission line connecting buses 2 and 4 very near to bus 4. The fault is cleared by opening the circuit breakers at the two ends of this line. Find the critical clearing time for various values of H (15)</p> 	CO 5	BT-3	Apply
5	<p>A double circuit line feeds an infinite bus from a power station. If a fault occurs on one of the lines and the line is switched off, derive an expression for the critical clearing angle.</p>	CO 5	BT-4	Analyze

CO1:	Ability to model the power system components under steady state operating condition.
CO2:	Ability to understand and apply iterative techniques for power flow analysis.
CO3:	Ability to model and carry out symmetrical short circuit studies on power system.
CO4:	Ability to model and find the parameters needed for protection of power system
CO5:	Ability to model and analyze stability problems in power system